

SL-710A

Single Needle Direct Drive Straight Lock
Stitcher with Thread Trimmer



Model

SL-710A-□□□ - □□□

Device				
	Thread Trimmer	Quick back Device	Thread wiper	Automatic presser lifter
3	○	○	—	—
4	○	○	○	—
9	○	○	○	○

Lower thread detector	
0	—
1	○

Application	
S	—
1	Difficult-to-sew and light materials
3	Medium materials
5	Heavy materials

Operation panel	
	B-40
	B-100

Specifications

		□□S	□□1	□□3	□□5
Application		—	Difficult-to-sew and light materials	Medium materials	Heavy materials
Max. speed		3,000 rpm	4,000 rpm	5,000 rpm	3,500 rpm
Max. stitch length		4.2 mm			5 mm
Height of Presser foot	Manual	6 mm			
	Knee	13 mm			
	Auto	10 mm			
Type and height of feed dog		—	4 row 0.8 mm	3 row 0.8 mm	3 row (rough) 1.2 mm
Needles		—	DB × 1NS #9 DP × 5NS #9	DB × 1 #11 DP × 5 #11	DB × 1 #22 DP × 5 #22
Hook		RP hook	Rotary hook for thread trimming		
Bed size		476 × 178 mm			
Arm pocket size		266.5 × 134.5 mm			

Motor specifications

High sewing speed	220 rpm to the maximum (Changeable)
Low sewing speed	220 rpm
Front / continuous backtacking speed	220 rpm to 1,800 rpm (Changeable)
End backtacking speed	1,800 rpm
Motor	AC servomotor (3-phase / single-phase 4 pole 400 W, 100 240 V)
Control circuit	Microcomputer

Control box : MD721 (Single-phase), MD731 (3-phase)

Operating panel

B-40

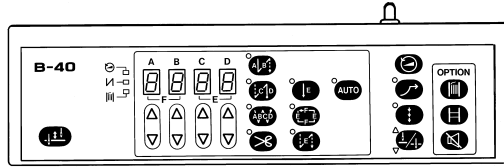

J80627-001

B-100

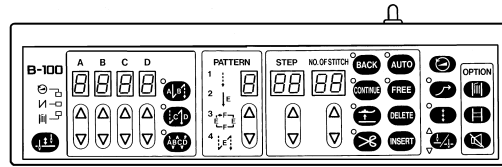

FOR JAPAN ONLY J80628-001
FOR EXPORT J80629-001

Basic function

		B-40	B-100
	Automatic sewing	○	○
	Start backtack (0-9)	○	○
	End backtack (0-9)	○	○
	Continuous backtack (0-9)	○	○
	Correction sewing	○	○
	Half stitch	○	○
	Sewing speed setting	○	○
	Slow start sewing	○	○
	Needle up stop / Needle down stop	○	○
	Lower thread detector (optional)	○	○

Pattern sewing

		B-40	B-100
	Normal lock stitch	○	○
	Fixed stitch (1-99)	○	○
	Name label stitch (1-99)	○	○
	Pleats presser stitch (1-99)	○	○
	Pattern stitch	—	○

Pattern setting

		B-40	B-100
	Automatic thread trimming	○	○
	Automatic presser foot lifting	—	○
	Back stitch	—	○
	Continuous stitch	—	○
	Step deletion	—	○
	Step insertion	—	○
	Temporarily cancel programming sewing	—	○

Options

Part name		Code
Presser foot lifting solenoid set A	With knee switch	S80008-001
Presser foot lifting solenoid set B	Without knee switch	S80009-001
Bobbin thread detector set		S80007-001
Thread wiper set		
Tension gauge set		183922-101
Auto bobbin changer		
Set for new synthetic fabric*	For -□□3 models	183910-201

* If changing -□□1 models to new synthetic fabric specifications, please use the following parts.

Rotary hook box assy S44338-901
 Cap screw S35786-001

Work table parts

Part name	Code
Standing operation 2 pedal #6 (Two pedals + kick pedal)	J80081-040
Standing operation 3 pedal #40 (Three pedals)	J80380-040
Spacer set	183504-009
Caster set	183501-001
Foot plug set, NDD (For control box)	J02953-001

Gauge parts list

3ROW



[Models, SL-7100, SL-710A, SL-7360, SL-737A]

用途 Application	針板 Needle plate		送り歯 Feed dog	押工組 Presser foot assy	
	記号 Mark				
薄・中厚物用 Light & medium-weight materials	B12	I53147-001 ø: 1.2 R: 0.2 T: 2.1	I46231-001 P: 1.15 H: 6	S36902-001 153037-201 長溝 Slot	
	B14	I46233-001 ø: 1.4 R: 0.2 T: 2.1		S36905-001 113280-101 面取り大 Chamfering(L)	
	NB14M	S29649-001 ø: 1.4 R: 0.2 T: 2.1		S38189-001 147531-101 面取り小 Chamfering(S)	
	NB16M	S29646-001 ø: 1.6 R: 0.2 T: 2.1		S36906-101 111856-101 長溝 Slot	
	B14	I46050-001 ø: 1.4 R: 0.2 T: 2.8		S07649-001 P: 1.15 H: 6.7	S38187-001 140957-101 面取り小 Chamfering(S)
	B14	I47238-001 ø: 1.4 R: 1 T: 2.8		S38188-001 143711-101 面取り小 Chamfering(S)	
	B16	I53190-001 ø: 1.6 R: 0.2 T: 2.8		S02742-001 P: 1.6 H: 6.7	S01904-001 テフロン押え Teflon
	B16	I47239-001 ø: 1.6 R: 1 T: 2.8			

GAUGE PARTS LIST

3ROW

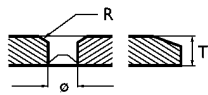
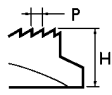
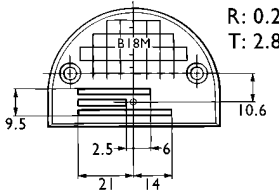
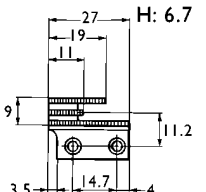
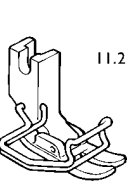
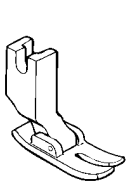
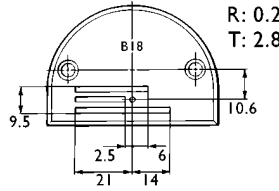
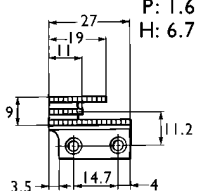
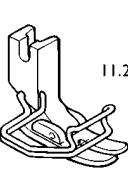
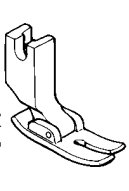
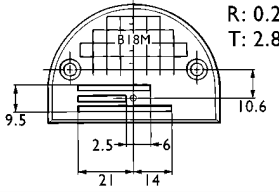
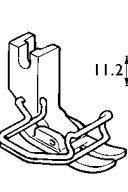
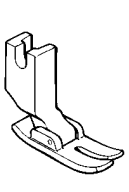
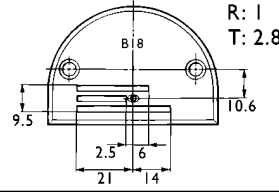
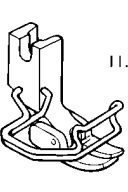
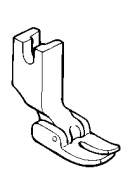
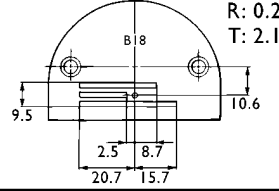
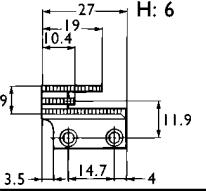
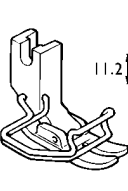
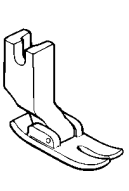
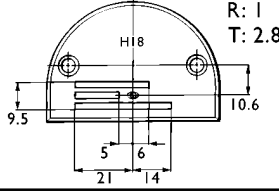
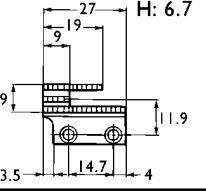
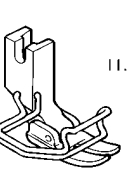
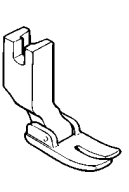
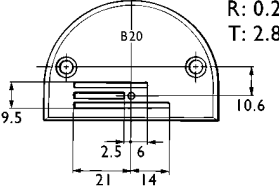
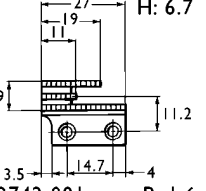
[Models, SL-7100, SL-710A, SL-7360, SL-737A]

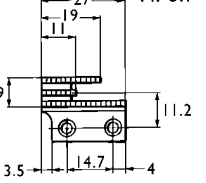

用途 Application	針板 Needle plate		送り歯 Feed dog	押工組 Presser foot assy	
	記号 Mark				
薄・中厚物用 Light & medium-weight materials	B18M	S29645-001  ø: 1.8 R: 0.2 T: 2.8	S07649-001  P: 1.15 H: 6.7	S36902-001 	I53037-201  長溝 Slot
	B18	I45971-001  ø: 1.8 R: 0.2 T: 2.8	S02742-001  P: 1.6 H: 6.7	S36905-001 	I13280-101  面取り大 Chamfering(L)
中厚物用 medium-weight materials	B18M	S29645-001  ø: 1.8 R: 0.2 T: 2.8		S38189-001 	I47531-101  面取り小 Chamfering(S)
	B18	I00266-001  ø: 1.8 R: 1 T: 2.8		S36906-101 	I11856-101  長溝 Slot
	B18	I46232-001  ø: 1.8 R: 0.2 T: 2.1	I46231-001  P: 1.15 H: 6	S38187-001 	I40957-101  面取り小 Chamfering(S)
	H18	I41096-001  ø: 1.8 R: 1 T: 2.8	I17442-001  P: 1.15 H: 6.7	S38188-001 	I43711-101  面取り小 Chamfering(S)
	B20	S11222-001  ø: 2 R: 0.2 T: 2.8	S07649-001  P: 1.15 H: 6.7	S01904-001 	テフロン押え Teflon
			S02742-001  P: 1.6 H: 6.7		

From the library of: Diamond Needle Corp

GAUGE PARTS LIST

3ROW

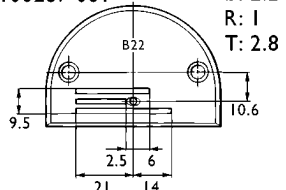
[Models, SL-7100, SL-710A, SL-7360, SL-737A]

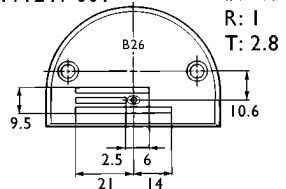
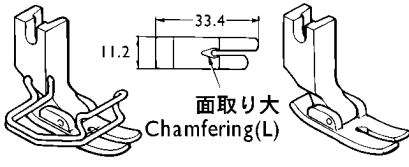
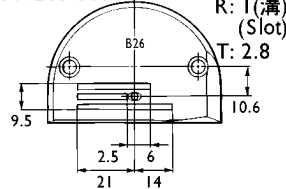
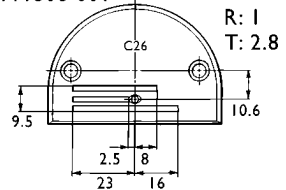
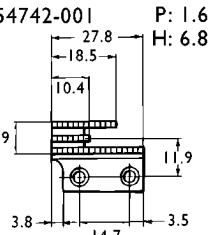
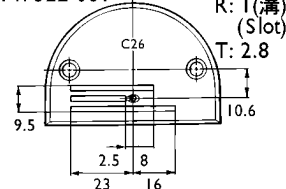
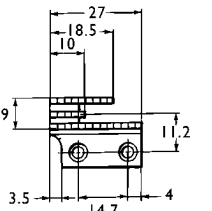
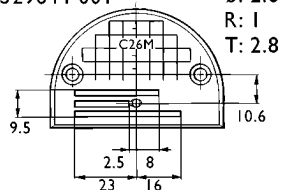
用途 Application	針板 Needle plate 記号 Mark	送り歯 Feed dog	押工組 Presser foot assy
厚物用 Heavy-weight materials	B22 100267-001  ø: 2.2 R: 1 T: 2.8	 S02743-001 P: 2.1 H: 6.7	S36904-001 145157-101  針落ち部のみ 面取りあり These presser foot have chamfering corner on the needle location
	B26 111241-001  ø: 2.6 R: 1 T: 2.8		S36905-001 113280-101  面取り大 Chamfering(L)
	B26 147245-001  ø: 2.6 R: 1(溝) T: 2.8 (Slot)		
	C26 111508-001  ø: 2.6 R: 1 T: 2.8		154742-001 P: 1.6 H: 6.8 
	C26 147322-001  ø: 2.6 R: 1(溝) T: 2.8 (Slot)		S02743-001 P: 2.1 H: 6.7 
	C26M S29644-001  ø: 2.6 R: 1 T: 2.8		

* If a feed dog measuring 11.9 mm from the screw hole center to tooth center is used, shift the feed bar crank and feed lifting crank 0.7 mm to the left.

GAUGE PARTS LIST

4ROW

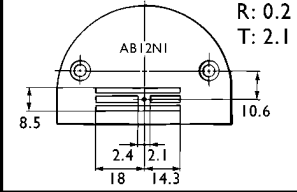
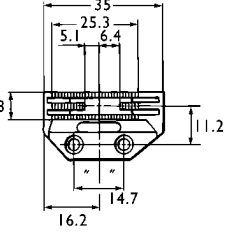
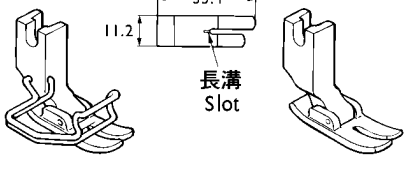
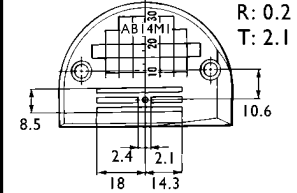

[Models, SL-7100, SL-710A, SL-7360, SL-737A]

用途 Application	針板 Needle plate 記号 Mark	送り歯 Feed dog	押工組 Presser foot assy
難素材用 Difficult-to-sew materials	AB12NI S38760-001  $\varnothing: 1.2$ $R: 0.2$ $T: 2.1$	S02748-001 P: 0.9 H: 6 	S38190-001 S35777-101  長溝 Slot
新素材用 Shin-gosen	AB14MI S35776-101  $\varnothing: 1.4$ $R: 0.2$ $T: 2.1$		

GAUGE PARTS LIST

4ROW

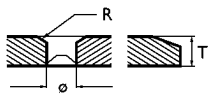
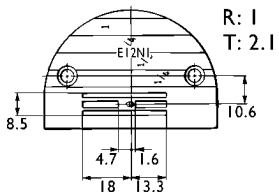

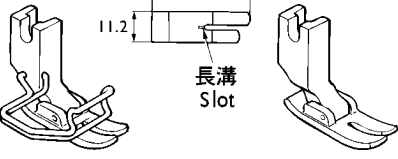
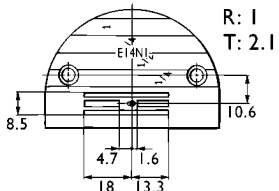
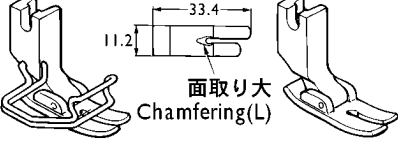
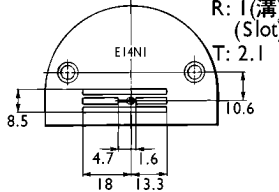
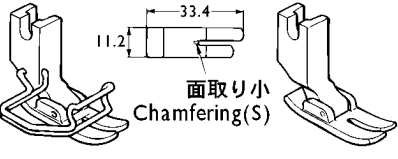
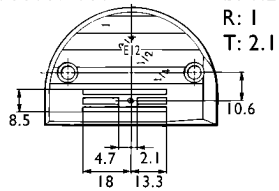
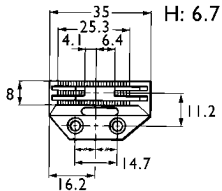
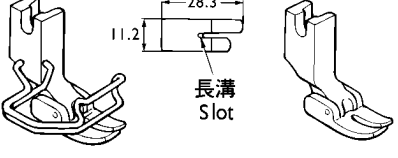
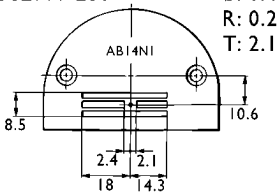
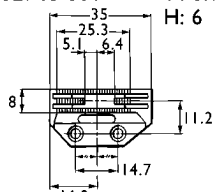
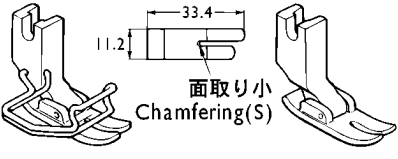
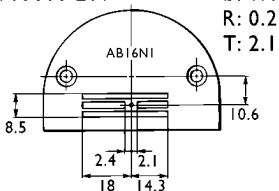
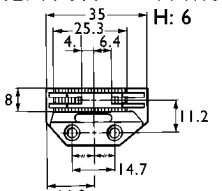
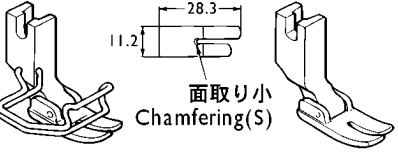
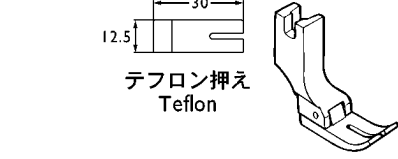
[Models, SL-7100, SL-710A, SL-7360, SL-737A]

用途 Application	針板 Needle plate		送り歯 Feed dog	押工組 Presser foot assy	
	記号 Mark				
薄・中厚物用 Light & medium-weight materials	E12NI	S03882-201 ø: 1.2 R: 1 T: 2.1 	S03885-001 P: 0.9 H: 6 	S36902-001 153037-201  長溝 Slot	
	E14NI	S03883-201 ø: 1.4 R: 1 T: 2.1 		S36905-001 113280-101  面取り大 Chamfering(L)	
	E14NI	159859-201 ø: 1.4 R: 1(溝) (Slot) T: 2.1 		S38189-001 147531-101  面取り小 Chamfering(S)	
	E12	S01107-101 ø: 1.2 R: 1 T: 2.1 		S13684-001 P: 1.6 H: 6.7 	S36906-101 111856-101  長溝 Slot
	AB14NI	S02999-201 ø: 1.4 R: 0.2 T: 2.1 		S02748-001 P: 0.9 H: 6 	S38187-001 140957-101  面取り小 Chamfering(S)
	AB16NI	S03000-201 ø: 1.4 R: 0.2 T: 2.1 		S02744-001 P: 1.15 H: 6 	S38188-001 143711-101  面取り小 Chamfering(S)
				S01904-001  テフロン押え Teflon	

GAUGE PARTS LIST

4ROW

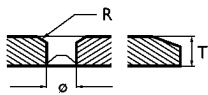
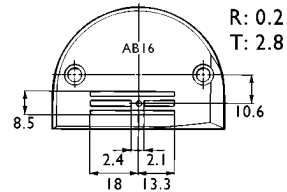
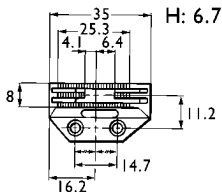
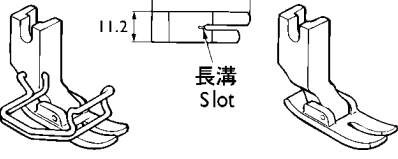
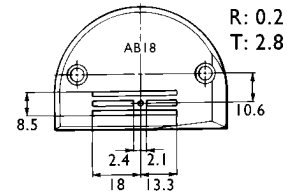
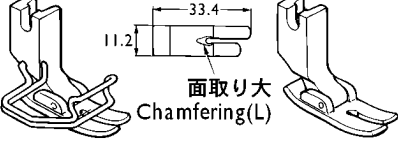
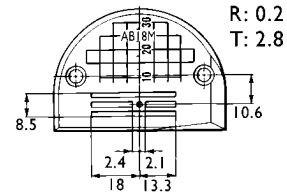
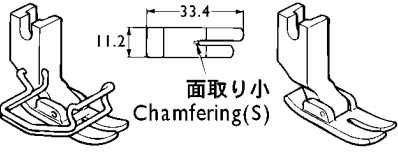
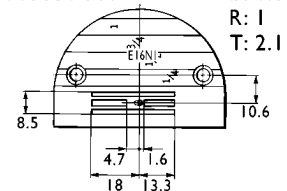
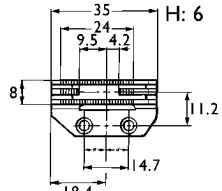
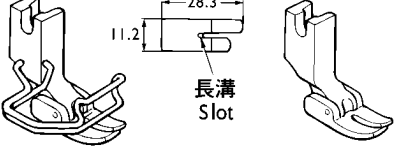
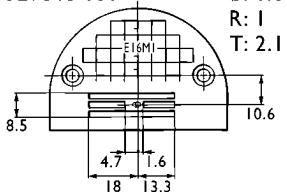
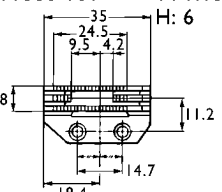
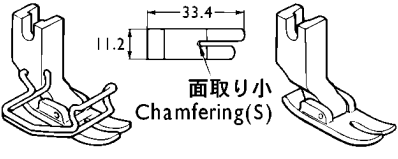
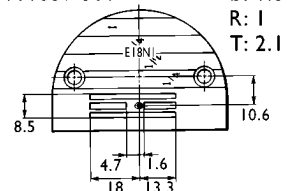
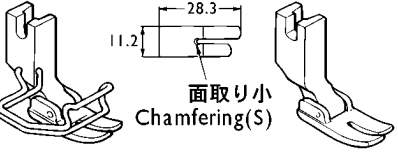
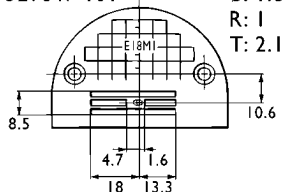
[Models, SL-7100, SL-710A, SL-7360, SL-737A]

用途 Application	針板 Needle plate		送り歯 Feed dog	押工組 Presser foot assy
	記号 Mark			
薄・中厚物用 Light & medium-weight materials	AB16	156115-001 	S13684-001 	S36902-001 153037-201 
	AB18	156116-001 		S36905-001 113280-101 
	AB18M	S31910-001 		S38189-001 147531-101 
	E16NI	S03884-301 	S03885-001 	S36906-101 111856-101 
	E16MI	S29648-101 	111860-101 	S38187-001 140957-101 
	E18NI	111859-301 		S38188-001 143711-101 
	E18MI	S29647-101 		S01904-001 

GAUGE PARTS LIST

4ROW



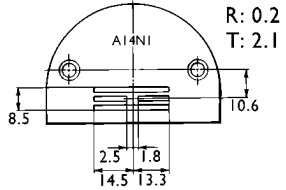
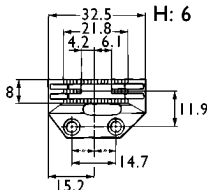
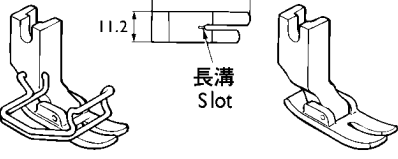
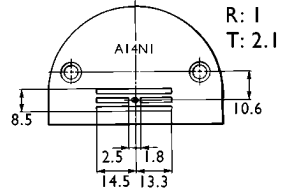
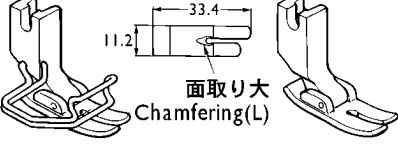
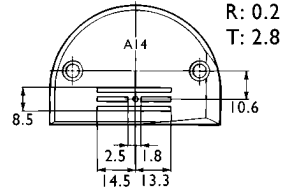
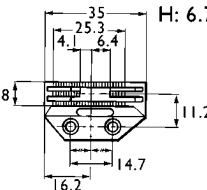
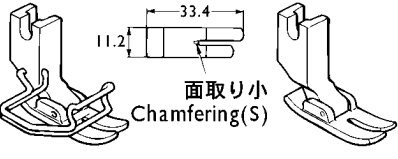
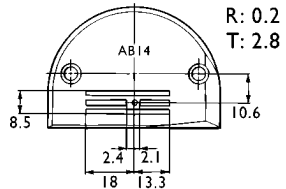
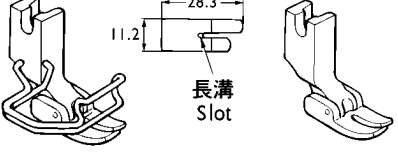
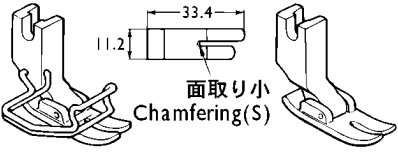
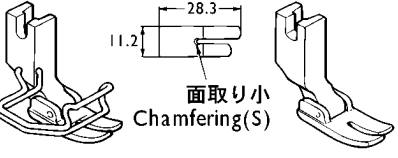
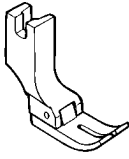

[Models, SL-7100, SL-710A, SL-7360, SL-737A]

用途 Application	針板 Needle plate 記号 Mark	送り歯 Feed dog	押工組 Presser foot assy
薄・中厚物用 Light & medium-weight materials	A14NI 146053-201  ø: 1.4 R: 0.2 T: 2.1	111898-001 P: 1.15  H: 6	S36902-001 153037-201  長溝 Slot
	A14NI 100603-201  ø: 1.4 R: 1 T: 2.1		S36905-001 113280-101  面取り大 Chamfering(L)
	A14 155676-001  ø: 1.4 R: 0.2 T: 2.8	S13684-001 P: 1.6  H: 6.7	S38189-001 147531-101  面取り小 Chamfering(S)
	AB14 156114-001  ø: 1.4 R: 0.2 T: 2.8		S36906-101 111856-101  長溝 Slot
			S38187-001 140957-101  面取り小 Chamfering(S) S38188-001 143711-101  面取り小 Chamfering(S) S01904-001  テフロン押え Teflon

GAUGE PARTS LIST

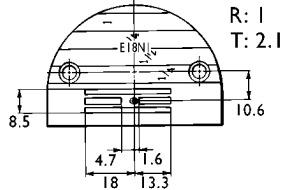
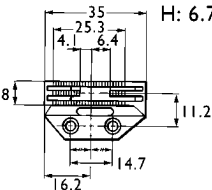
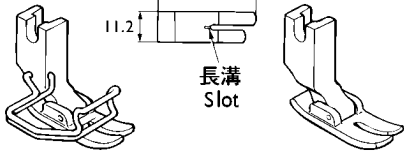
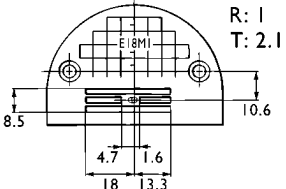
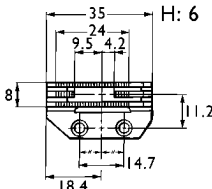
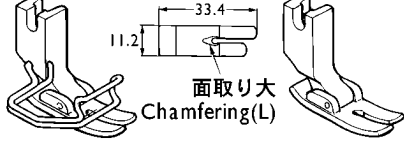
4ROW

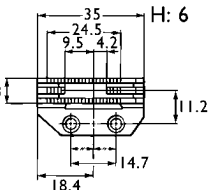
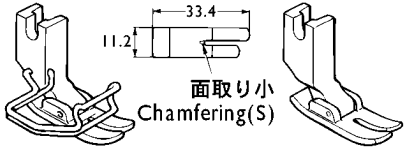
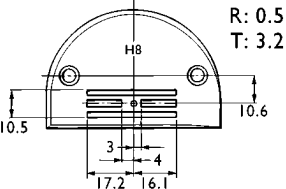
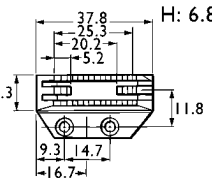
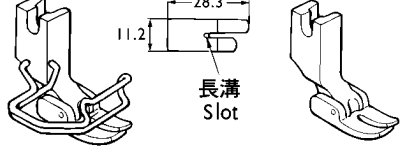
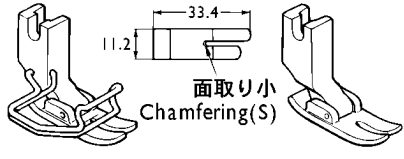
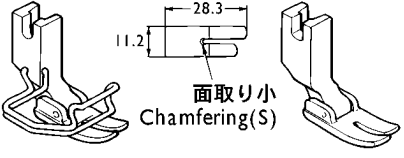
[Models, SL-7100, SL-710A, SL-7360, SL-737A]

用途 Application	針板 Needle plate 記号 Mark	送り歯 Feed dog	押工組 Presser foot assy
薄・中厚物用 Light & medium-weight materials	E18NI 111859-301  ø: 1.8 R: 1 T: 2.1	S13684-001 P: 1.6  H: 6.7	S36902-001 153037-201  長溝 Slot
	E18MI S29647-101  ø: 1.8 R: 1 T: 2.1	S03885-001 P: 0.9  H: 6	S36905-001 113280-101  面取り大 Chamfering(L)
	H18 S30103-001  ø: 1.8 R: 0.5 T: 3.2	S25822-001 P: 1.15  H: 6	S38189-001 147531-101  面取り小 Chamfering(S)
	H18 S30103-001  ø: 1.8 R: 0.5 T: 3.2	S25822-001 P: 1.8  H: 6.8	S36906-101 111856-101  長溝 Slot
			S38187-001 140957-101  面取り小 Chamfering(S)
			S38188-001 143711-101  面取り小 Chamfering(S) S01904-001 テフロン押え Teflon 

From the library of: Diamond Needle Corp

GAUGE PARTS LIST

4ROW

[Models, SL-7100, SL-710A, SL-7360, SL-737A]

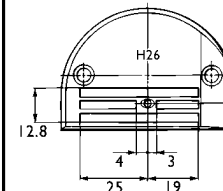
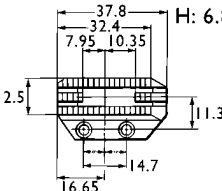
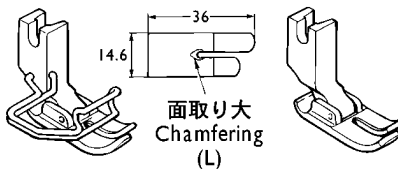
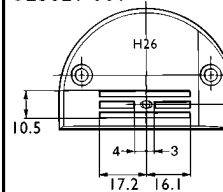
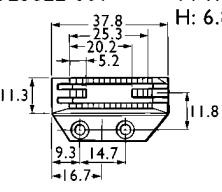
用途 Application	針板 Needle plate 記号 Mark	送り歯 Feed dog	押工組 Presser foot assy
厚物用 Heavy-weight Materials	H26 150792-001  $\varnothing: 2.6$ $R: 1$ $T: 3.2$	150793-001  $P: 1.8$ $H: 6.8$	S36903-001 150789-101  面取り大 Chamfering (L)
	H26 S25821-001  $\varnothing: 2.6$ $R: 1$ $T: 3.2$	S25822-001  $P: 1.8$ $H: 6.8$	